

# Box 485-4

Installation Manual

**CE**

## Table of Contents

1. Introduction .....	3
2. Electric connections .....	3
3. Programming .....	4
3.1. Programming positions .....	4
3.2. Default programming .....	4
3.3. Address (ID number) of slave keypads (100 and 101) .....	5
3.4. Address (ID number) of Box 485-4 (102) .....	5
3.5. Relay mask for relay 1 - 4 (103 – 106) .....	5
3.6. Pre-activation time for slave relay 3 (107) .....	5
3.7. Pre-activation time for slave relay 4 (108) .....	5
3.8. Relay activation time for exit button (109) .....	6
3.9. Allowed time zones for slave keypads (110 - 122) .....	6
3.10. Active mask (123) .....	6
4. Installation example .....	7
5. Technical Specifications .....	7

## 4. Installation example

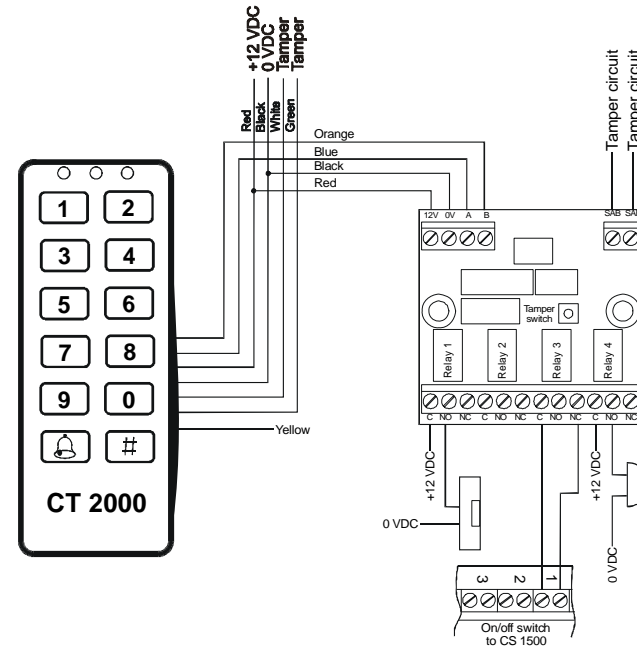

## 5. Technical Specifications

Supply Voltage:	12 VDC
Voltage Range:	10 to 15 VDC
Ripple Voltage:	max. 500 mVpp
Current Consumption:	20 to 100 mA
Relay outputs:	4 NC/C/NO (max. 24V / 1A)
Tamper switch:	mechanical contact (100 mA)
Operation temperatures:	0° C to 85° C
Humidity:	max. 85% RF
Dimensions (W x H x D):	65,5 x 88,5 x 29 mm

### 3.8. Relay activation time for exit button (109)

Value in this programming position specifies how long these of the Box 485-4's relay outputs, which are programmed to be active in this situation, shall react to an activation of the bell button on the first or second slave keypad. Programming time intervals are 1/4 second, e.g. 4 = 1 sec. and 16 = 4 sec.

Value in programming position 109 is by default set to 4, which equals to 1 second.

### 3.9. Allowed time zones for slave keypads (110 – 122)

These programming positions are reserved for future development of the system and are not used at the moment.

They are by default set to 255.

Note that programming positions 110 to 122 are reserved for future development. They must always be set to value 255, otherwise Box 485-4 does not work.

### 3.10. Active mask (123)

This programming position is reserved for future development of the system and is not used at the moment.

It is by default set to 127.

Note that programming position 123 is reserved for future development. It must always be set to value 127, otherwise Box 485-4 does not work.

## 1. Introduction

Box 485-4 is a door control unit, used together with CT 2000 keypad. The unit is delivered in a white joint box, space for cabling included.

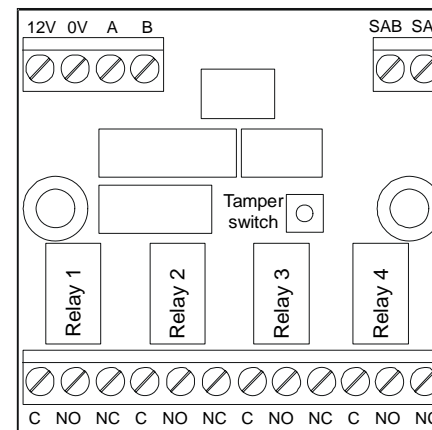

Box 485-4 is typically used if one CT 2000 keypad is to control more than one output.

Typical applications:

- where CT 2000 normal functions shall be combined with keypad's bell button;
- silent attack alarm combined with f. ex. access to alarm on/off switch or door opening;
- access to alarm on/off switch, if extra safety required.

## 2. Electric connections

12V	+12 VDC
GND	0 VDC (minus)
A	Connection to data bus via RS 485, in-/ output A, <u>blue core</u>
B	Connection to data bus via RS 485, in-/ output B, <u>orange core</u>
SAB	Tamper switch
SAB	Tamper switch
C	Relay output – common
NO	Relay output – normally open
NC	Relay output – normally closed

### 3. Programming

Box 485-4 is from the factory delivered with a standard programming. Further programming can be made through the PC-interface (PCI 1).

#### 3.1. Programming positions

Position	Programming
100	Address (ID number) of first slave (keypad);
101	Address (ID number) of second slave (keypad);
102	Address (ID number) of Box 485-4;
103	Relay mask for relay 1;
104	Relay mask for relay 2;
105	Relay mask for relay 3;
106	Relay mask for relay 4;
107	Pre-activation time of slave relay 3 (master relay is relay 1);
108	Pre-activation time of slave relay 4 (master relay is relay 2);
109	Relay activation time for exit button, 1/4 second;
110 to 122	Allowed time zones for the first and second slave keypad, Reserved for future system development;
123	Active mask, Reserved for future system development.

#### 3.2. Default programming

Position	Value	Programming
100	1	Address (ID number) of first slave (keypad);
101	1	Address (ID number) of second slave (keypad);
102	200	Address (ID number) of Box 485-4;
103	inactive	Relay mask for relay 1 is group 0, 1, 2 and 3;
104	inactive	Relay mask for relay 2 is group 4, 5, 6 and 7;
105	inactive	Relay mask for relay 3 is group 8, 9, 10 and 11;
106	inactive	Relay mask for relay 4 id group 12;
107	0	Pre-activation time of slave relay 3 is 0;
108	0	Pre-activation time of slave relay 4 is 0;
109	4	Relay activation time for exit button, 1 second;
110 to 122	255	Reserved for future system development, <b>(must be value 255);</b>
123	127	Reserved for future system development, <b>(must be value 127).</b>

#### 3.3. Address (ID number) of slave keypads (100 and 101)

Keypads (CT 2000) connected to RS 485 data bus are distinguished from each other by assigning them each an address (ID number). When a code is entered on one of the keypads in an installation, carrying an address (ID number), Box 485-4 reacts in accordance with its programming.

As default the programming positions 100 and 101 are set to 1 for both the first and second slave keypad.

#### 3.4. Address (ID number) of Box 485-4 (102)

Box 485-4, just like keypads, must carry an address (ID number), to enable division between different units on RS 485 data bus.

Address in the programming position 102 is by default set to 200.

#### 3.5. Relay mask for relays 1 – 4 (103 – 106)

This programming positions specify how the Box 485-4's relay outputs shall react to entering valid user codes on CT 2000.

There are no values in these programming positions. Please use the overview on screen (use PC-interface PCI 1 and PC computer).

#### 3.6 Pre-activation time for slave relay 3 (107)

Value in this programming position specifies how long relay output 3 shall stay active, if relay output 1 is active (master relay).

Value in position 107 is by default set to 0, which equals to 0 seconds.

#### 3.7. Pre-activation time for slave relay 4 (108)

Value in this programming position specifies how long relay output 4 shall stay active, if relay output 2 is active (master relay).

Value in position 108 is by default set to 0, which equals to 0 seconds.